Methods of test for pallet joints —

Part 3:

Determination of strength of pallet joints

Méthodes d'essai des assemblages de palettes —

Partie 3: Détermination de la résistance des assemblages de palettes



PDF disclaimer

This PDF file may contain embedded typefaces. In accordance with Adobe's licensing policy, this file may be printed or viewed but shall not be edited unless the typefaces which are embedded are licensed to and installed on the computer performing the editing. In downloading this file, parties accept therein the responsibility of not infringing Adobe's licensing policy. The ISO Central Secretariat accepts no liability in this area.

Adobe is a trademark of Adobe Systems Incorporated.

Details of the software products used to create this PDF file can be found in the General Info relative to the file; the PDF-creation parameters were optimized for printing. Every care has been taken to ensure that the file is suitable for use by ISO member bodies. In the unlikely event that a problem relating to it is found, please inform the Central Secretariat at the address given below.

© ISO 2002

All rights reserved. Unless otherwise specified, no part of this publication may be reproduced or utilized in any form or by any means, electronic or mechanical, including photocopying and microfilm, without permission in writing from either ISO at the address below or ISO's member body in the country of the requester.

ISO copyright office
Case postale 56 • CH-1211 Geneva 20
Tel. + 41 22 749 01 11
Fax + 41 22 749 09 47
E-mail copyright@iso.ch
Web www.iso.ch

Printed in Switzerland

Foreword

ISO (the International Organization for Standardization) is a worldwide federation of national standards bodies (ISO member bodies). The work of preparing International Standards is normally carried out through ISO technical committees. Each member body interested in a subject for which a technical committee has been established has the right to be represented on that committee. International organizations, governmental and non-governmental, in liaison with ISO, also take part in the work. ISO collaborates closely with the International Electrotechnical Commission (IEC) on all matters of electrotechnical standardization.

International Standards are drafted in accordance with the rules given in the ISO/IEC Directives, Part 3.

Draft International Standards adopted by the technical committees are circulated to the member bodies for voting. Publication as an International Standard requires approval by at least 75 % of the member bodies casting a vote.

Attention is drawn to the possibility that some of the elements of this part of ISO 12777 may be the subject of patent rights. ISO shall not be held responsible for identifying any or all such patent rights.

International Standard ISO 12777-3 was prepared by Technical Committee ISO/TC 51, *Pallets for unit load method of materials handling*.

ISO 12777 consists of the following parts, under the general title *Methods of test for pallet joints*:

- *Part 1: Determination of bending resistance of pallet nails, other dowel-type fasteners and staples*
- *Part 2: Determination of withdrawal and head pull-through resistance of pallet nails and staples*
- *Part 3: Determination of strength of pallet joints*

Introduction

This part of ISO 12777 was developed using methods that enable the user to select from a range of tests that best fits the particular problem or area of the pallet under analysis. Some are suitable for routine quality control and some are designed for laboratory use. Where characteristics of wood used in pallet joints are required then ISO 3133 and related standards as given in clause 2 may be used.

In general the tests if used as routine quality control tests only require the measurement of ultimate load, while if the tests are undertaken as prototype tests in a laboratory, then they also require measurement of deflection or distortion in the joint plotted during the application of the load.

Methods of test for pallet joints —

Part 3:

Determination of strength of pallet joints

1 Scope

This part of ISO 12777 specifies methods of determining the resistance of pallet joints primarily to static load by determining the strength and stiffness of nailed or stapled joints, wood to wood, wood to wood-based materials, wood to plastics or plastics to plastics.

This part of ISO 12777 is applicable to joints with all types of nails up to 7 mm in diameter (including plain shank, helical, annular ring, barbed and twisted) and with staples.

2 Normative references

The following normative documents contain provisions which, through reference in this text, constitute provisions of this part of ISO 12777. For dated references, subsequent amendments to, or revisions of, any of these publications do not apply. However, parties to agreements based on this part of ISO 12777 are encouraged to investigate the possibility of applying the most recent editions of the normative documents indicated below. For undated references, the latest edition of the normative document referred to applies. Members of ISO and IEC maintain registers of currently valid International Standards.

ISO 445:1996, *Pallets for materials handling — Vocabulary*

ISO 1133:1997, *Plastics — Determination of the melt mass-flow rate (MFR) and the melt volume-flow rate (MVR) of thermoplastics*

ISO 1183:1987, *Plastics — Methods for determining the density and relative density of non-cellular plastics*

ISO 3130:1975, *Wood — Determination of moisture content for physical and mechanical tests*

ISO 3131:1975, *Wood — Determination of density for physical and mechanical tests*

ISO 3133:1975, *Wood — Determination of ultimate strength in static bending*

ISO 8611-1:—¹⁾, *Pallets for materials handling — Flat pallets — Part 1: Test methods*

ISO/TR 11444:1995, *Quality of sawn wood used for the construction of pallets*

ISO 12777-1:1994, *Methods of test for pallet joints — Part 1: Determination of bending resistance of pallet nails, other dowel-type fasteners and staples*

ISO 12777-2:2000, *Methods of test for pallet joints — Part 2: Determination of withdrawal and head pull-through resistance of pallet nails and staples*

1) To be published.

3 Terms and definitions

For the purposes of this part of ISO 12777, the terms and definitions given in ISO 445 apply.

4 Requirements for testing of joints

4.1 Fasteners

Prior to the assembly of any joints made with nails or staples, the nail bending strength shall be determined in accordance with ISO 12777-1.

4.2 Timber

4.2.1 Selection

The timber shall either be selected in accordance with the pallet specification, or the test pieces shall be cut from pallets manufactured for eventual mass production, or a laboratory type specimen made using clear straight grain wood.

4.2.2 Comparative laboratory tests

For comparative tests on different types of nails or staples, these shall be driven into wood of carefully balanced density and grain structure in laboratory prepared specimens.

NOTE Samples from the same board may achieve this balance of density and grain structure.

4.2.3 Joints

Joints shall be cut so that areas into which the fasteners are embedded are free from knots, local grain disturbance, fissures and wane. Elsewhere the specimens shall be free from major defects which could lead to unrepresentative failure in the timber.

4.2.4 Moisture content

4.2.4.1 General

For quality control tests the moisture content shall be as per pallet specification after noting the requirements for tolerances of 5.2.

4.2.4.2 Method of measuring moisture content

For laboratory tests, the moisture content of the timber shall be determined using the "oven dry method" in accordance with ISO 3130, and its density in accordance with ISO 3131.

NOTE Moisture content may be determined by electrical resistance as described in EN 13183-2.

4.2.4.3 Genus and species

For laboratory tests, the identity of the genus and where possible the species shall be confirmed by anatomical examination. Where this cannot be done at the time of test, then a sample shall be retained for examination later.

4.2.5 Conditioning

Timber shall be conditioned and tested at $23\text{ °C} \pm 2\text{ °C}$, and as required in 5.1.1.

4.3 Wood-based sheet materials

4.3.1 Properties

Species mix, resin content, veneer or particle size, dimensional stability, density, moisture content and other properties which will effect the test result shall be determined. These are typically available from the manufacturer or supplier or specification of the product.

4.3.2 Conditioning

The specimens shall be tested at a temperature of $23\text{ °C} \pm 2\text{ °C}$.

4.4 Plastics and plastic-based material

4.4.1 Density

If the material is not of uniform density or if it exhibits grain effects, this shall be recorded, and separate tests conducted to measure the effect of such anisotropy. Density shall be measured in accordance with ISO 1183.

4.4.2 Melt mass-flow rate (MFR) and melt volume-flow rate (MVR)

Plastics shall have their melt mass-flow rate (MFR) and melt volume-flow rate (MVR) recorded in accordance with ISO 1133.

4.4.3 Conditioning

Test specimens shall be conditioned and tested at $+40\text{ °C} \pm 3\text{ °C}$ and $-20\text{ °C} \pm 3\text{ °C}$.

5 Sampling

5.1 Test specimens

5.1.1 General

There shall be a sufficiently large number of test specimens to permit statistical treatment of the results. A sample of 20 shall be considered a minimum for each type of wood joint where wood component sizes and fasteners do not change. The condition used shall be stated in the test report.

5.1.2 Wood

Wood specimens shall not be withdrawn from environmentally controlled conditions for longer than 1 h before testing. Specimens may be stored out of controlled conditions in the test area for up to 24 h provided they are wrapped in polyethylene sheeting.

5.1.3 Plastics

For plastics, assemble test specimens at $23\text{ }^{\circ}\text{C} \pm 2\text{ }^{\circ}\text{C}$. Plastics not undergoing high or low temperature conditioning (as given in 4.4.3) shall be maintained at all times within the band $23\text{ }^{\circ}\text{C} \pm 2\text{ }^{\circ}\text{C}$.

5.2 Preparation

The preparation of samples and testing of wood or wood based materials shall take into account the following factors:

- a) assembly of test joints shall be at or above the highest moisture content expected at the time of pallet assembly;
- b) the testing shall take place at the appropriate moisture level selected from one of the following target levels:
 - over 28 % (above fibre saturation point),
 - (20 ± 2) % (frequent pallet specification level),
 - (15 ± 2) %,
 - (12 ± 2) %.

5.3 Rate of loading

Unless otherwise stated, maximum test loads shall be applied at the rate of between 10 mm/min and 50 mm/min. When the rate of loading is controlled, the low end of this range shall be used.

6 Test methods

6.1 Separation test

6.1.1 Principle

Force is applied to a pallet joint to evaluate its stiffness and strength under tension.

6.1.2 Materials

Pallet joints shall be selected according to the appropriate criteria in clause 4.

6.1.3 Apparatus

6.1.3.1 Simple test rig, as illustrated in Figure 1, consisting of **clamps**, **load applicator** and a **deformation measurement device**.

6.1.4 Preparation and storage of test samples and test pieces

Preparation and preservation of test samples and test pieces shall be as stated in clause 5.

6.1.5 Procedure

Figures 1 and 2 show the stirrup clamps gripping the block, stringerboard or stringer. Clamp 1 is actuated by hydraulic or other means, while clamp 2 is loose and provides the restraint for the board. The relative movement of clamp 1 upwards and clamp 2 downwards shall be measured by suitable means between the two (e.g. 3 in Figure 1). Testing continues until the joint will no longer support an increasing load.

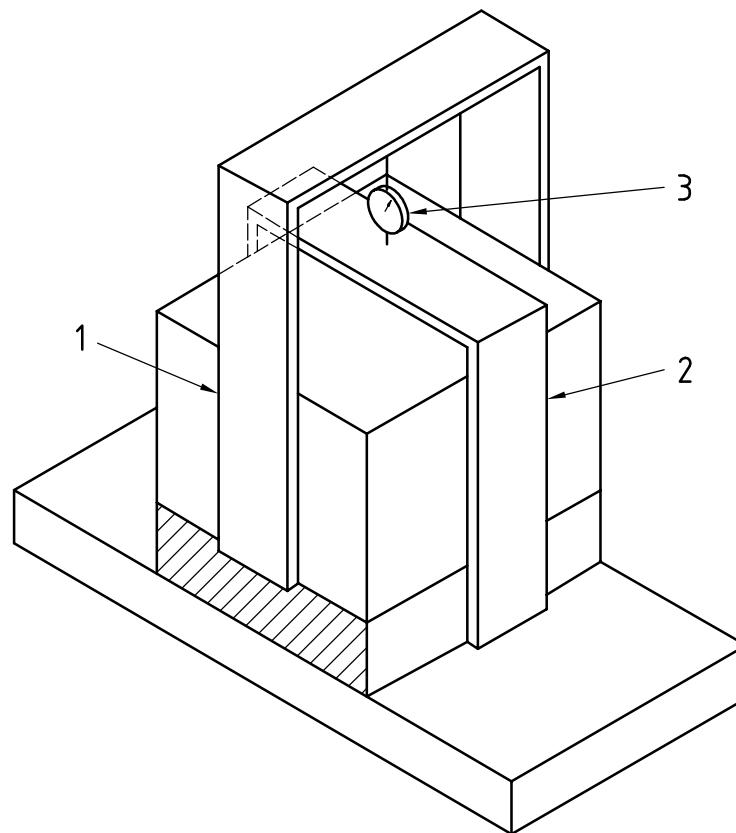

Key

- 1 Stirrup clamp 1
- 2 Stirrup clamp 2
- 3 Movement gauge (deformation measurement device)

Figure 1 — Schematic diagram showing the principle of the stirrup clamp joint separation test method

6.2 Shear test — Linear — Method 1

6.2.1 Principle

Force is applied to a butted joint of a full perimeter, 9-block pallet, to evaluate its resistance to shearing under load in a racking situation (see Figure 3).

6.2.2 Materials

Pallet joints shall be selected according to the appropriate criteria in clause 4.

6.2.3 Apparatus

6.2.3.1 Simple test rig, as illustrated in Figure 3, consisting of **steel straps**, **load applicator** and a **deformation measurement device**.

6.2.4 Preparation and storage of test samples and test pieces

Preparation and preservation of test samples and test pieces shall be as stated in clause 5.

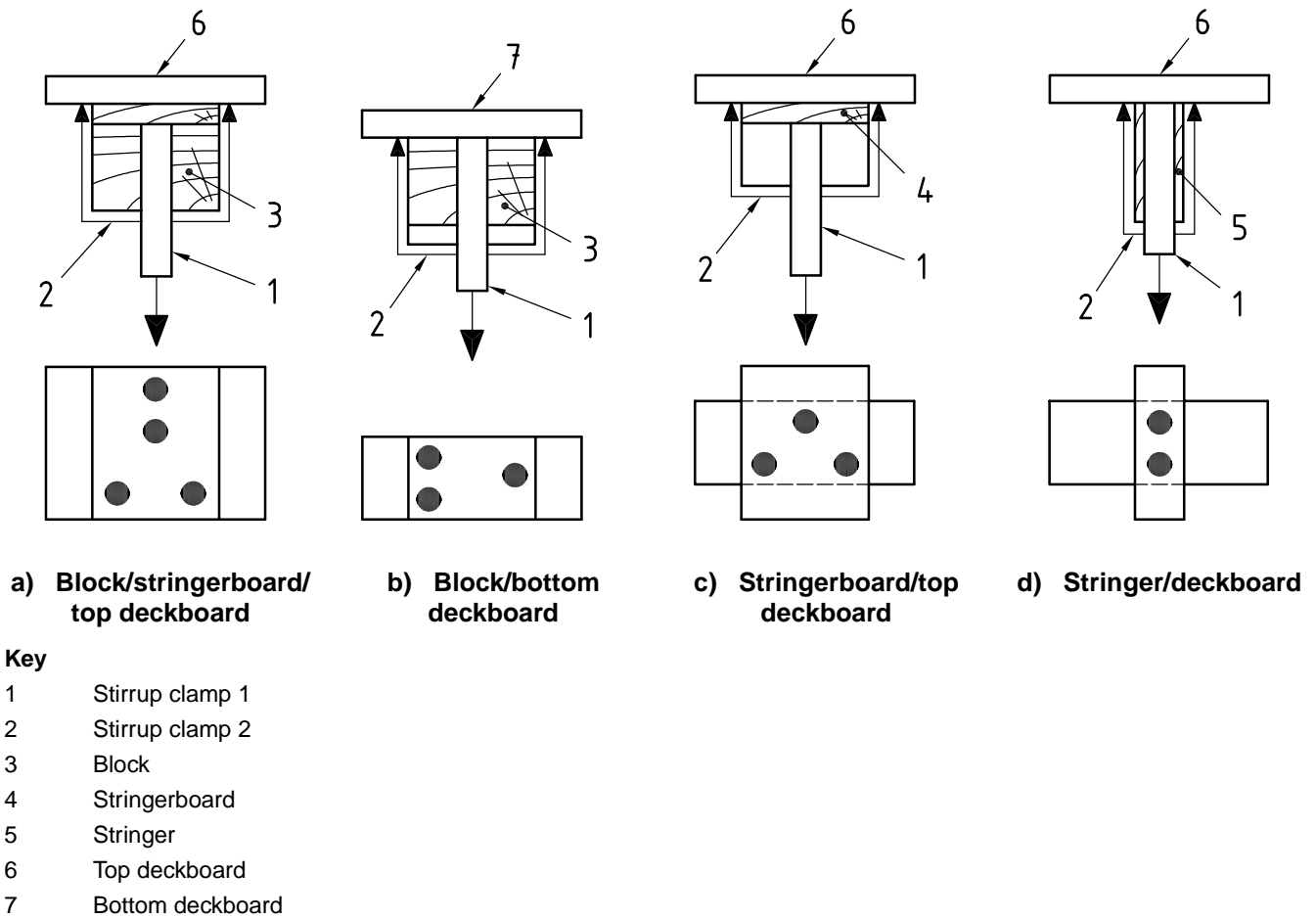
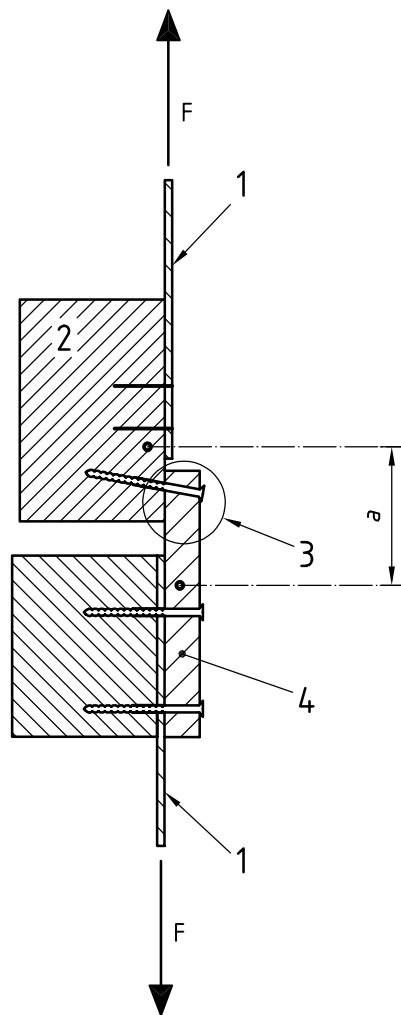

Figure 2 — Schematic diagram showing the clamp and load application for each pallet joint geometry during separation tests

6.2.5 Procedure

Figure 3 shows the evaluated joint at 3 with steel straps (1) held in the mechanical or hydraulic jaws of a universal tensile test machine. The movement of the board (4) relative to the block (2) shall be measured (*a*). Testing continues until the joint no longer supports an increasing load.

**Key**

- 1 Steel straps
- 2 Block
- 3 Evaluated joint
- 4 Board
- a is the relative movement

Figure 3 — Shear test on a specially manufactured specimen which simulates the butted joint in a full perimeter base pallet

6.3 Shear test — Linear — Method 2

6.3.1 Principle

Force is applied to evaluate the shearing resistance of other joints in pallets subjected to horizontal shear stress.

6.3.2 Materials

Pallet joints shall be selected according to the appropriate criteria in clause 4.

6.3.3 Apparatus

6.3.3.1 Simple test rig, as illustrated in Figure 4, consisting of clamps, load applicator and a deformation measurement device.

6.3.4 Preparation and storage of test samples and test pieces

Preparation and preservation of test samples and test pieces shall be as stated in clause 5.

6.3.5 Procedure

The block or stringer is supported and a load shall be applied at “F” and deformation readings (d) shall be taken (see Figure 4). Testing continues until the joint no longer supports an increasing load.

The tests may be duplicated to simulate different designs with wood grain in line or perpendicular to force “F”.

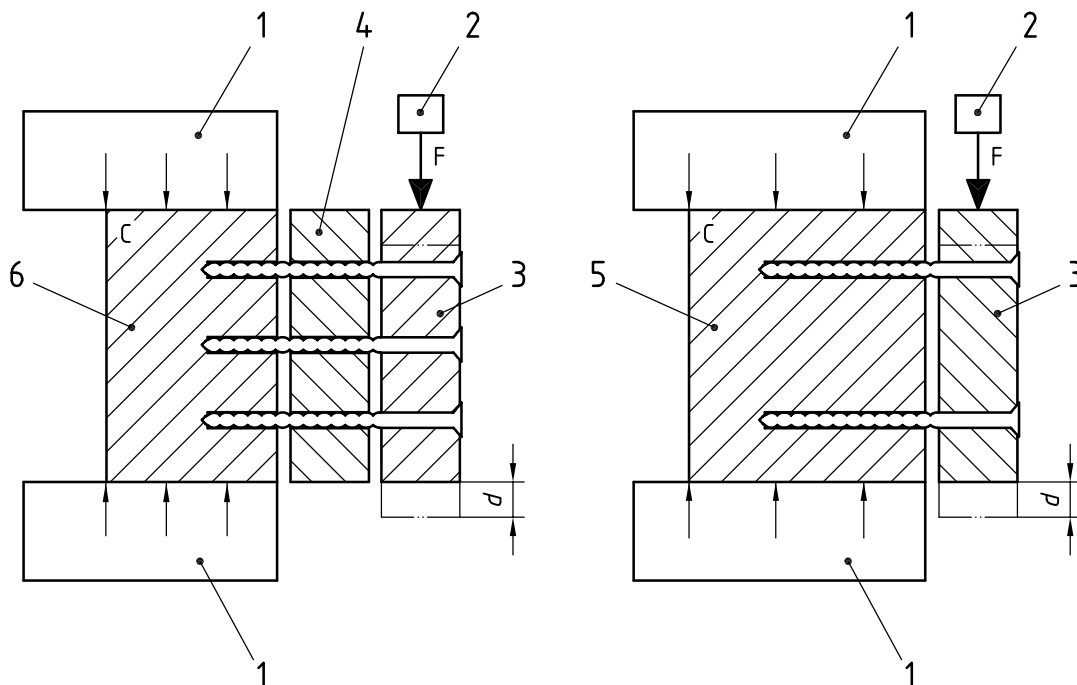

- Key**
- 1 Clamps
 - 2 Load applicator
 - 3 Deckboard
 - 4 Stringerboard
 - 5 Block or stringer
 - 6 Block

Figure 4 — Shear tests for most block or stringer pallet joints

6.4 Shear test — Rotational

6.4.1 Principle

Force is applied to evaluate the torsional shear resistance of a pallet joint as may occur when pallets are dropped or impacted by forked equipment.

6.4.2 Materials

Pallet joints shall be selected according to the appropriate criteria in clause 4.

6.4.3 Apparatus

6.4.3.1 Simple test rig, as illustrated in Figure 5, consisting of **clamps**, **load applicator** and a **deformation measuring device**.

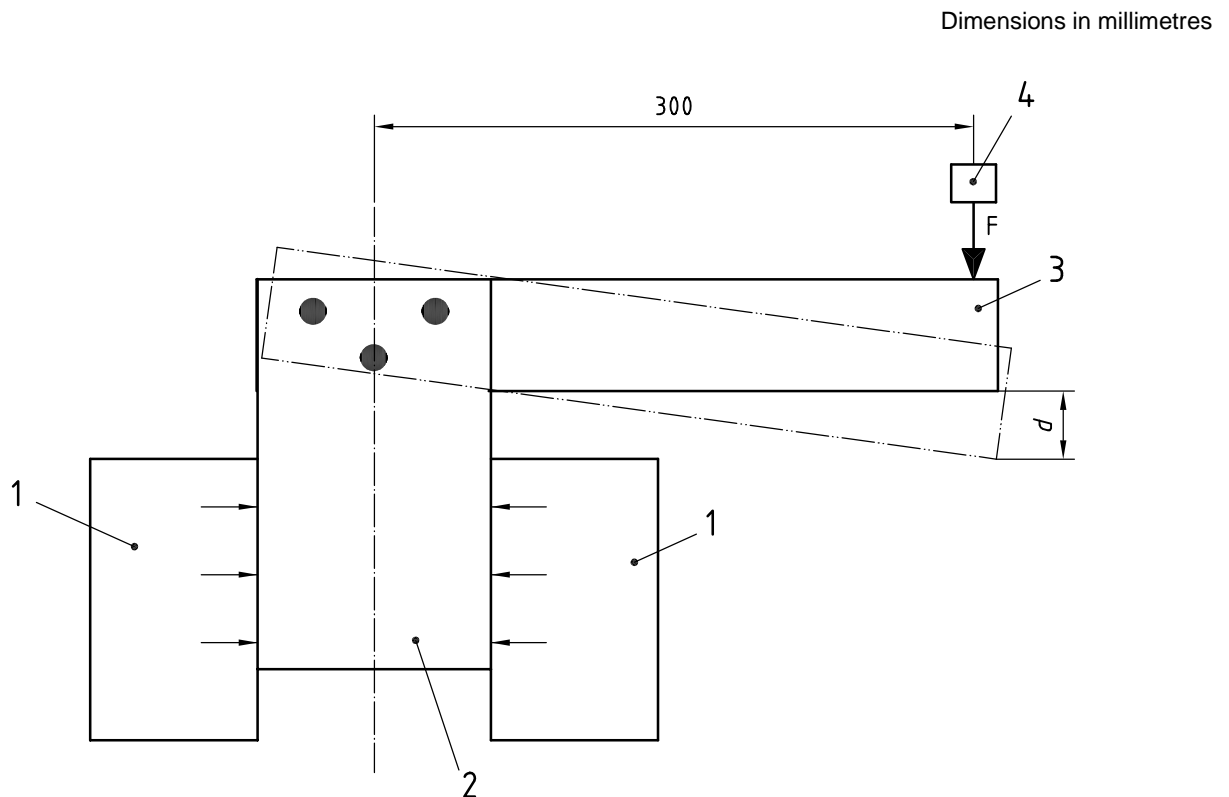

Key

- 1 Clamps
- 2 Top and bottom deckboards
- 3 Stringer
- 4 Load applicator

Figure 5 — Rotational shear test on a 3-member specimen cut from a 2-way entry stringer pallet

6.4.4 Preparation and storage of test samples and test pieces

Preparation and preservation of test samples and test pieces shall be as stated in clause 5.

6.4.5 Procedure

The load shall be applied at “F” to the stringer in increments of no more than 100 N and readings of deformation (d) shall be taken at each load increment as shown in Figure 5. It is essential that the moment applied to the joint through force “F” is equal between specimens, therefore the length from specimen centre-line shall be standardized at 300 mm.

6.5 Out-of-plane loading

6.5.1 Principle

Force is applied to a joint to evaluate joint resistance of an out of plane bending as will occur when pallet decks deform under load.

6.5.2 Materials

Pallet joints shall be selected according to the appropriate criteria in clause 4.

6.5.3 Apparatus

6.5.3.1 Simple test rig, as illustrated in Figure 6, consisting of **restraint**, **load applicator** and a **deformation measuring device**.

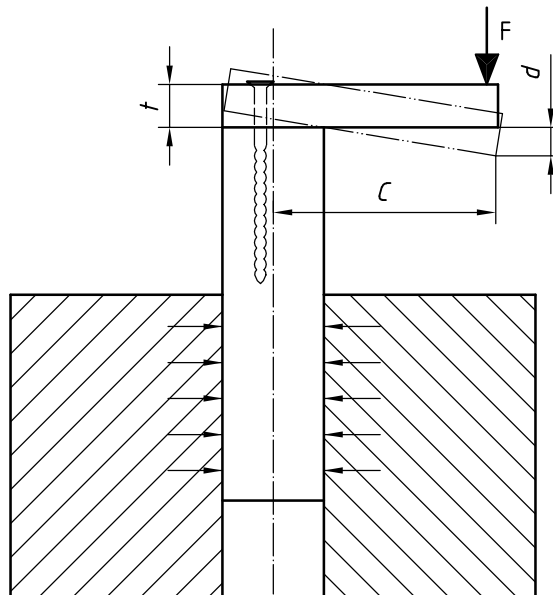

Figure 6 — Test method for point or uniform load on a 2-member specimen

6.5.4 Preparation and storage of test samples and test pieces

Preparation and preservation of test samples and test pieces shall be as stated in clause 4.

6.5.5 Procedure

The load F is applied at distance C which is based on $4t = C$, where t is the thickness of the deckboard. The value of C at which to apply force F is determined from Table 1. The load shall be applied at F in increments of no more than 100 N and readings of deflection d shall be taken at each load increment.

To avoid minor changes of C with small changes in specimen deck thickness, Table 1 sets 3 threshold limits.

Table 1 — Determination of C for out-of-plane joint bending test

Board thickness mm	Reference thickness mm	Distance C mm
10-16	16	64
17-20	20	80
21-30	30	120

7 Test report

7.1 General requirements

The following shall be recorded:

- fastening bending strength in accordance with ISO 12777-1;
- full specification of manufactured materials including overall dimensions and detailed shank profile of nails;
- number and location of fastener per joint;
- depth of fastener penetration into specimens;
- accuracy of applied loading and deflection measurement;
- rate of test loading and length of time that the loads are maintained;
- strength, stiffness and failure modes.

All materials and joints shall be characterized during testing. If this information is not available, it shall be referred to in the test report.

7.2 Particular requirements for plastics

The following shall be recorded:

- the MFR, MVR and density of plastics used;
- full details of profile of loaded sections;
- compound.

7.3 Particular requirements for wood

The following shall be recorded:

- moisture content of wood specimens at assembly (electrical resistance method);
- moisture content immediately after test (oven drying method) in accordance with ISO 3130 and specimen density (oven drying method) in accordance with ISO 3131;
- identity of the grade and species.

Bibliography

- [1] EN 13183-2, *Moisture content of a piece of sawn timber — Part 2: Estimation by electrical resistance method*

